

auto electrical parts

Technical Information Sheet

Part No. 0-420-94

A powerful 54inch (1372mm) 300 watt (100x3W) 20,000 Lumen, 10-30 volt Epistar LED Work lamp. Black powder coated die cast aluminum case, polycarbonate lens. Protected to IP69K. Spot/Flood Combo beam. 30cm Flying Leads. Approx Life: 30,000 hours. EMC Approved. Mounting: Roof Mount.



Technical Drawing (not to scale)

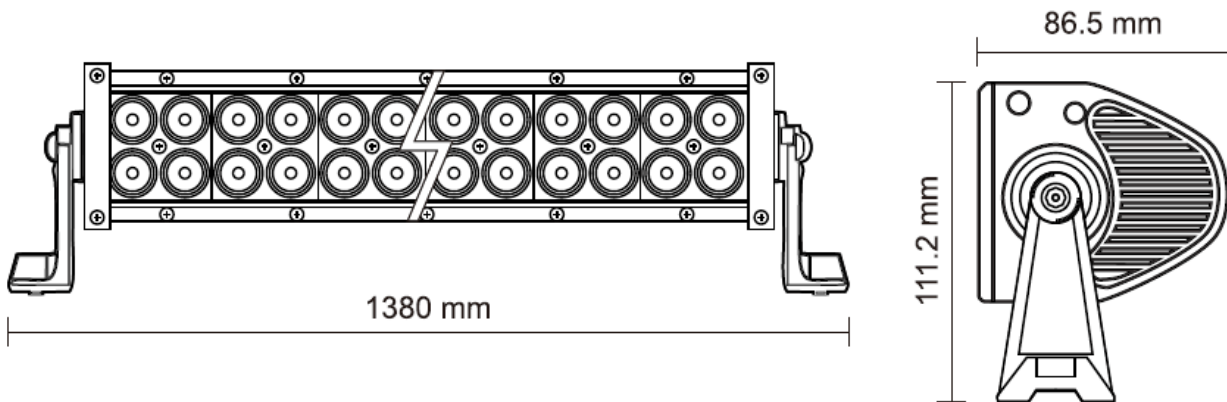

Specification

Type	LED Work Lamp
Voltage	10-30 volt dc
Current Draw	7.5A @ 12VDC. 3.7A @ 24VDC
LEDs	Epistar 100 x 3W (6000K)
Lumens	20,000Lm
Housing	Die cast aluminium
Bracket	Die cast aluminium
Lens	Polycarbonate
Degree of protection	IP69K
Operating temperature	-40°C to +50°C
Weight	4.8KG
Dimensions	See above diagram
Approval	CE, EMC

The information contained in this document is correct to the best of our knowledge at the time of printing. However, specifications may change at any time without notice.